

## Schody nástupiště

31 Doloplazy

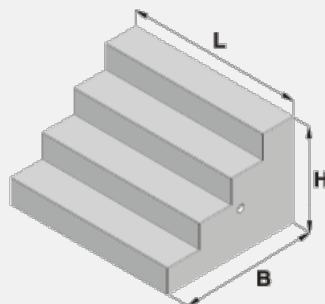

Trademark	Dimensions (cm)			Concrete Class	Volume (m3)	Weight (kg)
	L	B	H			
DZH 120/19	130	103	75	C 30/37-XF4	0,4307	1012